

Dynamic Simulation and Analysis of a Low-Voltage Micro-Grid

Wei-Tzer Huang, Kai-Chao Yao

Department of Industrial Education and Technology
National Changhua University of Education
Changhua 500, Taiwan
e-mail: vichuang@cc.ncue.edu.tw, kcyao@cc.ncue.edu.tw

Chun-Ching Wu, Shyi-Wen Wang

Department of Electrical Engineering
Chienkuo Technology University
Changhua 500, Taiwan
e-mail: wugch001@yahoo.com.tw

Abstract—This paper aims to analyze the dynamic operations of a low-voltage microgrid with various distributed energy resources. The sample system is composed of a low-voltage microgrid with a 30 kVA micro-hydro generator, a 30 kVA diesel engine generator, a 30 kVA gas engine generator, and a 15 kVA micro-wind turbine generator as well as loads. The dynamic models of individual components are established and tested to ensure accuracy, and then the aforementioned components are integrated to form a microgrid dynamic simulation system in the Matlab/Simulink environment. The system dynamic operations of the proposed microgrid are discussed. The results are expected to provide distribution engineers with the necessary information on the dynamic characteristics of the AC low-voltage microgrids. Further, the results are helpful for the development of microgrids in Taiwan.

Keywords- Microgrid, Distributed Energy Resources, Micro-Hydro Generator, Dynamic Analysis, Complex Power.

I. INTRODUCTION

Generally, a power system is composed of three vertical parts: generation, transmission, and distribution. The generation systems of large-scale thermal units almost always use fossil fuels. At the end of 2010, the total installed capacity of the power generation units in Taiwan was 40.912 GW, of which 30.717 GW was the installed capacity of thermal units, accounting for 75% of the total installed capacity [1]. Due to the higher proportion of thermal units, carbon dioxide and other greenhouse gas emissions in the generation system cannot be ignored. Emission of greenhouse gases is a serious environmental concern in many other countries. In addition, the power energy transmitted from the source to the receiving end in a traditional centralized generation structure causes significant transmission loss. For example, the power loss in transmission and distribution systems of Taipower was about 4.76% of the total power generation in 2011 [1]. Consequently, reducing greenhouse gas emissions and ensuring power saving by changing the generation structure is a vital issue, and other solutions are needed to improve system operating efficiency. One possible solution is to develop clean energy and highly efficient power systems. In this regard, microgrids have certain advantages [2]. Microgrids are composed of distributed energy resources (DERs), which include renewable or non-renewable energy generation systems, dispersed storage systems, and

controllable loads [3-4]. The DERs in microgrids can provide power for nearby loads, and this kind of system can also be operated in islanded or grid-connected modes [5]. Microgrids have gradually become a trend in power system development. Thus, exploring and discussing their dynamic and steady-state operating characteristics would prove worthwhile.

The operations of microgrids can be divided into islanded or grid-connected modes depending on the system operating conditions. In general, they are operated normally in grid-connected mode, that is, they are linked to the upstream power grid through the point of common coupling (PCC) by a static switch. Once a fault occurs in the upstream power grid or under normal scheduled maintenance, the microgrids will be operated in islanded condition. Therefore, understanding the operating characteristics and possible conditions of the microgrids through simulation and analysis, especially in islanded operation mode, is essential. The results will also be helpful for related research on and development of microgrids.

In this paper, a microgrid modified from the low-voltage AC 400 V microgrid used in the European Union (EU) was adopted as the sample system [6-7]. The simulation and analysis system was established in the Matlab/Simulink environment to accomplish the dynamic and steady-state analysis in islanded operation condition.

II. SYSTEM STRUCTURE AND PARAMETER SETTING

A. System Structure

Figure 1 shows the single-line diagram of the low-voltage AC 400 V microgrid. The system was a modified version of the EU “Microgrids” project with Contract ENK5-CT-2002-00610. In this sample system, the nominal voltage in upstream power grid is 20 kV, and the short-circuit capacity at the PCC is assumed as 300 MVA. The rated capacity of this MV/LV distribution transformer is 400 kVA. The conductor size of the feeder main is a 120 mm² Al XLPE; other conductor sizes are listed in Figure 1. The system has 12 buses, and the longest distance from Bus 1 to Bus 10 is 345 m. Bus 1 is assigned as the swing bus. The others are load buses, namely, Bus 8 (residential load), Bus 9 (residential load), Bus 10 (industrial load), Bus 12 (commercial load), and Bus 13 (residential load). The system also includes four DERs, and the total installed capacity is

105 kVA. The locations and capacities of the DERs interconnected to the network are as follows:

- A 30 kVA micro hydro-generator is connected to Bus 2 with a three-phase inverter.
- A 15 kVA micro wind-turbine generator is connected to Bus 9 with a three-phase inverter.
- A 30 kVA gas engine generator is connected to Bus 9 with a three-phase inverter.

- A 30 kVA diesel engine generator is connected to Bus 12 with a three-phase inverter.

This sample system was modeled by corresponding mathematical equations in the Matlab/Simulink environment, as shown in Figure 2, and the simulation system was used to simulate the complex power flow profiles from the grid-connected mode to islanded mode.

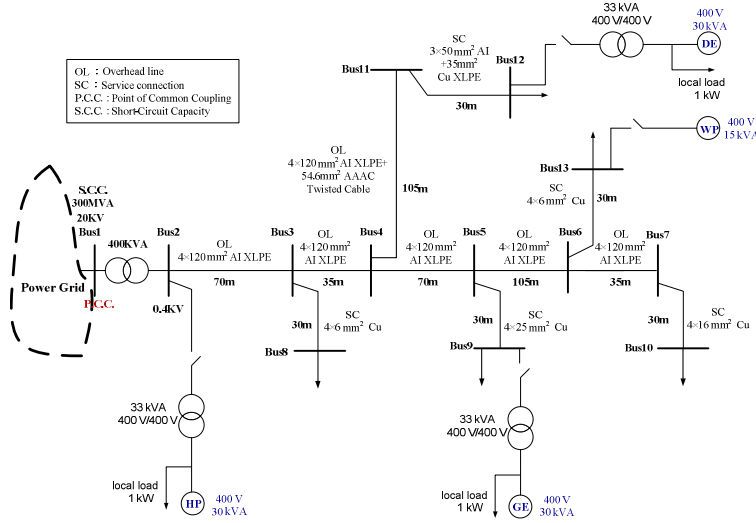

Figure 1. Single line diagram of the low-voltage micro-grid

B. Parameter Setting

The system was modeled in Matlab/Simulink. Therefore, the equivalent source, distribution transformer, feeders, and loads were modeled by a SimPowerSystems tool box. Meanwhile, the models of DERs in this paper were derived through related mathematical equations and were established as individual blocks. These models are described as follows.

The micro-hydro generator model is shown in Figure 3. Figure 4 presents the diesel-engine generator model. The gas engine generator model is illustrated in Figure 5. The micro-wind turbine generator model is depicted in Figure 6. The parameters of the above component models are listed in [6]. Moreover, the load data are summarized in Table I. Finally, the related parameters were set in Matlab/Simulink to accomplish the simulation and analysis.

TABLE I. LOAD DATA

Bus No.	Load	Complex Power (kW+jkvar)
Bus 8		2.49+j1.54
Bus 9		9.08+j5.61
Bus 10		9.61+j5.94
Bus 12		13.000+j8.041
Bus 13		2.46+j1.52

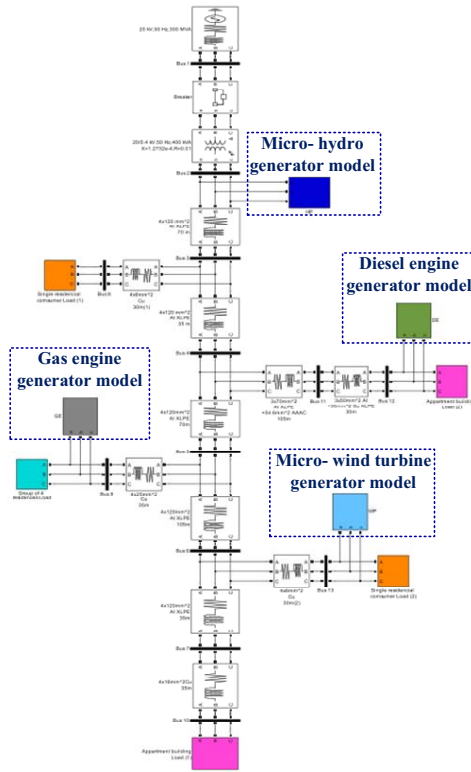

Figure 2. Simulation system modeling in Matlab/Simulink

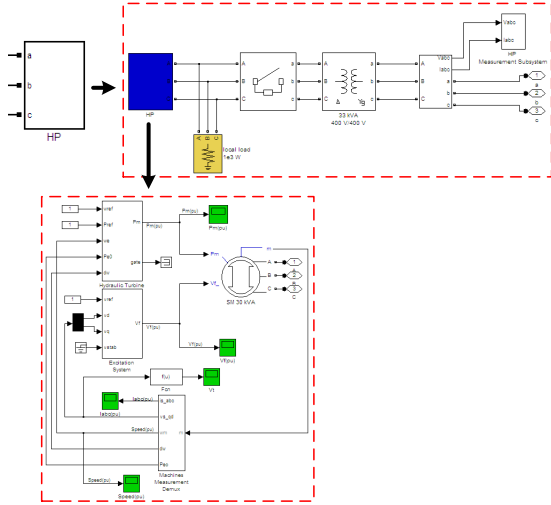

Figure 3. Micro-hydro generator model

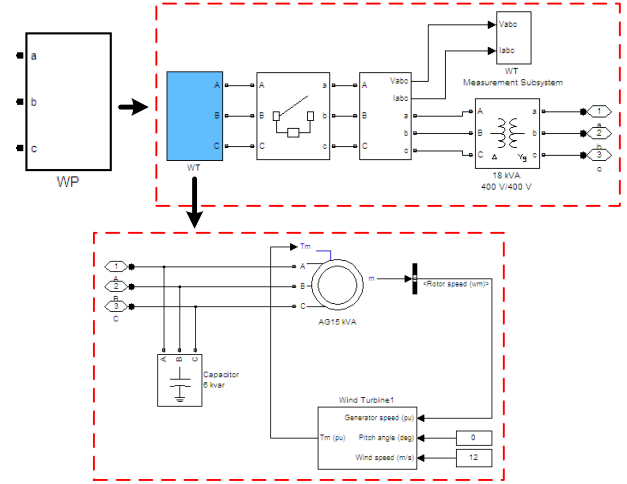

Figure 6. Micro-wind turbine generator model

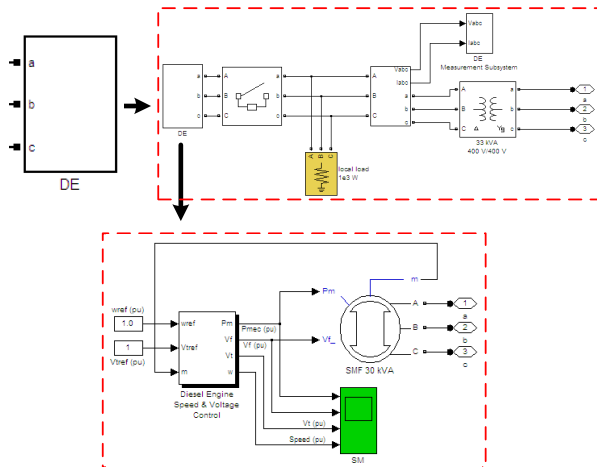

Figure 4. Diesel-engine generator model

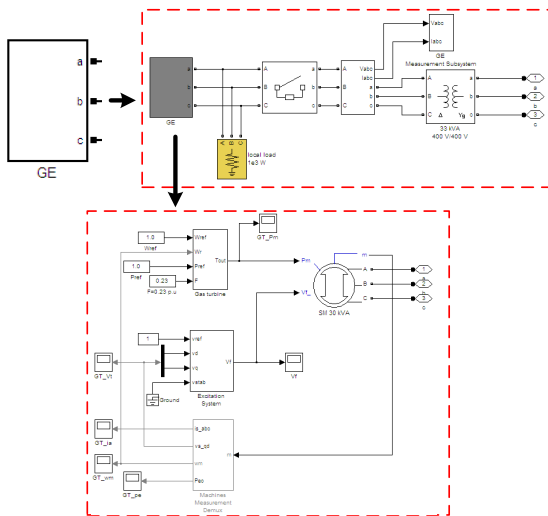

Figure 5. Gas engine generator model

III. DISCUSSION OF THE SIMULATION RESULTS

Under normal operating conditions, the microgrid is in grid-connected operation mode. Thus, the load demand can be supplied from both the upstream power grid and DERs. However, when the microgrid is forced to operate in islanded condition, the load demand only relies on the DERs. To maintain system stability, the magnitude and frequency of the voltage must remain stable, and power balance is important. If the load demand is greater than the power generated by the DERs, the magnitude of the bus voltage and system frequency will keep falling. On the contrary, if the load demand is less than the power generated by the DERs, the magnitude of the bus voltage and system frequency will keep rising until power balance is achieved.

The principle of power balance plays a vital role in power system operation. In this paper, the simulation focused on the complex power variations during the operating state transfer from grid-connected mode to islanded mode. The simulation is based on the assumption that the micro-hydro generator and micro-wind turbine generator are operating in full load. Another assumption is that the gas and diesel engine generators are operating in coordination as a swing bus to maintain the balance in the system power. Furthermore, the load demand is assumed to be less than the total installed capacity of DERs. The simulation results are presented in Figures 7 to 11. The operating transfer time is shown to be 4 seconds. Therefore, the complex power variations illustrate that the power fed from the upstream power grid gradually becomes zero at 4 seconds, as shown in Figure 7. Simultaneously, the power generated from the DERs gradually increase until system power balance is reached, as shown in Figures 8 to 11. The simulation results can adequately reflect the physical phenomenon of the

practical system. They prove that the theory and component models proposed in this paper are accurate.

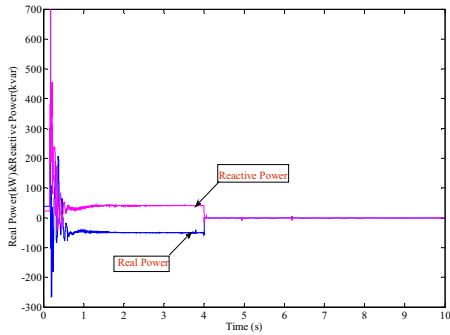

Figure 7. Complex power fed from the power grid

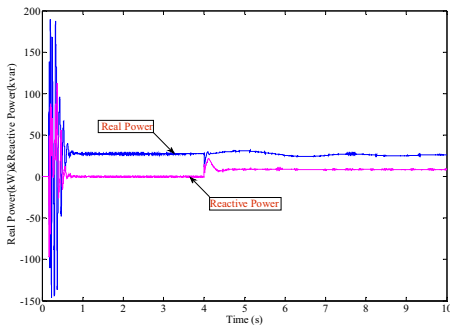

Figure 8. Complex power variations of the micro-hydro generator

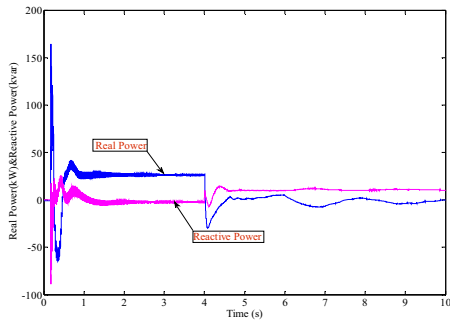

Figure 9. Complex power variations of the diesel engine generator

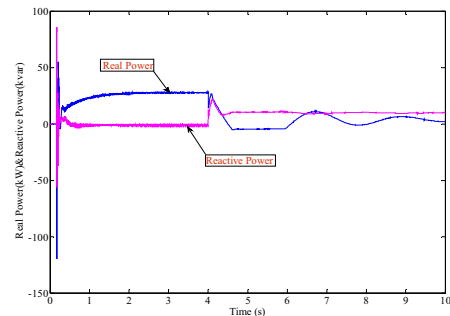

Figure 10. Complex power variations of the gas engine generator

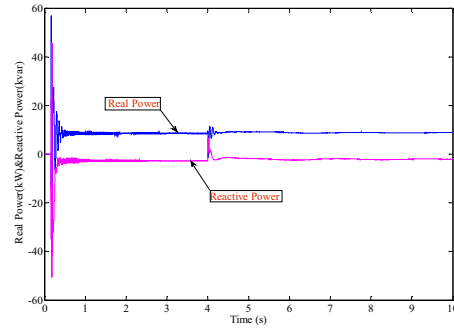

Figure 11. Complex power variations of the micro-wind turbine generator

IV. CONCLUSION

This paper accomplishes the modeling and dynamic simulation of a low-voltage microgrid with four various DERs. The simulation results show that the derived DER models are accurate, and the system established by these models in Matlab/Simulink is also accurate. At the same time, the outcomes conform to expectations. Consequently, the established simulation system can be used to analyze more complex operating conditions of microgrids in the near future. The outcomes provide distribution engineers with information on the dynamic characteristics of AC low-voltage microgrids. Moreover, the present results are helpful in providing a reference in the development of microgrids in Taiwan.

ACKNOWLEDGMENT

The authors would like to thank the National Science Council of Taiwan, R.O.C., for the financial support under Grant No. NSC-97-2221-E-270-014-MY3.

REFERENCES

- [1] Website: <http://www.taipower.com.tw/indexE.htm>
- [2] R. H. Lasseter, and P. Paigi, "Microgrid: A Conceptual Solution," IEEE Power Electronics Specialists conference on Volume 6, 20-25 June 2004, pp. 4285 – 4290.
- [3] R.H.Lasseter, Fellow, "MicroGrids," IEEE Power and Energy Magazine, Volume 5, issue4, July-Aug. 2007 Page(s):78 – 94.
- [4] Khaled A. Nigim, and Wei-Jen Lee, "Micro Grid Integration Opportunities and Challenges," Power Engineering Society General Meeting, IEEE, 24-28 June 2007 Page(s):1 – 6.
- [5] S. Papathanassiou, N. Hatziaegyriou, K. Strunz, "A Benchmark Low Voltage Micro-grid Network" Proc. CIGRE Symposium "Power Systems with Dispersed Generation", Athens, April 2005.
- [6] EU Project "MICROGRIDS: Large Scale Integration of Micro-Generation to Low Voltage Grids(ENK5-CT-2002-00610),"Website:<http://microgrids.power.ece.ntua.gr/>.
- [7] S. Papathanassiou, N. Hatziaegyriou, K. Strunz, "A Benchmark Low Voltage Micro-grid Network" Proc. CIGRE Symposium "Power Systems with Dispersed Generation", Athens, April 2005.