

Application of SIMULINK to Analyze the Unbalanced Operation Characteristics of a Three-Phase Transformer with Non-Identical Winding Impedances

W. C. Yang

Department of Electrical Engineering
Taipei Chengshih University of Science and Technology
R.O.C

W. T. Huang

Department of Industrial Education and Technology
National Chunghua University of Education
R.O.C

W. L. Kao

Department of Electrical Engineering
Taipei Chengshih University of Science and Technology
R.O.C

Abstract--The aim of this paper is to introduce the application of SIMULINK to analyze the unbalanced operation characteristics of a three-phase transformer with non-identical winding impedances. SIMULINK is popular professional simulation software in power industry and departments of electrical and electronic engineering of colleges. If the winding impedances of a three-phase transformer are not identical, unbalanced problems will be produced in power systems. In this paper, the simulation technique for a three-phase transformer with non-identical winding impedances is presented. The unbalanced operation characteristics of a three-phase transformer with non-identical winding impedances are also presented and discussed here.

Keywords--SIMULINK; unbalanced characteristic; transformer; winding impedance

I. INTRODUCTION

Three-phase transformers are electric devices. Their main tasks are to reduce the high voltage on primary side to a low voltage and to supply balanced three-phase electric power to customers [1]. At present, three-phase transformers are widely applied in power systems of utilities and industry plants. They affect the power supply quality and stability largely.

In order to reduce manufacturing costs, three-phase transformers are usually manufactured by three single-phase transformers [2]. Theoretically, the winding impedances of the three single-phase transformers are identical. In fact, the three winding impedances may not be identical due to various factors. If a power system adopts a three-phase transformer with non-identical winding impedances to supply three-phase electric power, unbalanced operation problems will be produced. Hence, how to get the unbalanced operation characteristics of a three-phase transformer with non-identical winding impedances is an important task for power engineers.

SIMULINK is professional software for simulating power systems or power devices [3]. It is popular with power industry and departments of electrical and electronic engineering of colleges. In this paper, the simulation technique for a three-phase transformer with non-identical winding impedances is presented. The unbalanced operation characteristics of a three-phase transformer with non-identical winding impedances are also presented and discussed here.

II. EQUIVALENT CIRCUIT

A three-phase transformer consists of three single-phase transformers. The windings on high-voltage and low-voltage sides of the three single-phase transformers can be connected with delta or wye connection, respectively. A three-phase transformer with delta-wye connection is shown in Figure 1. Generally, the delta connection is the primary side which is connected to a high voltage source. The wye connection is the secondary side which produces low voltage for customers. Delta-wye transformers are widely adopted in power stations of utilities and industry plants. Hence, they are adopted by this paper to present the unbalanced operation characteristics of a three-phase transformer.

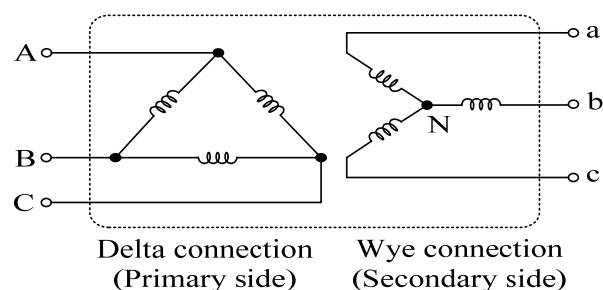

FIGURE I. A THREE-PHASE TRANSFORMER WITH DELTA-WYE CONNECTION.

For simulating the unbalanced operation characteristics of a delta-wye three-phase transformer, its equivalent circuit has been developed by the coupling-free technique [4]. The equivalent circuit of a delta-wye three-phase transformer is presented in Figure 2. The symbols y_a , y_b and y_c represent the leakage impedances of phase A, B and C windings of the delta-wye three-phase transformer, respectively. The units of the three leakage impedances are all per unit (pu).

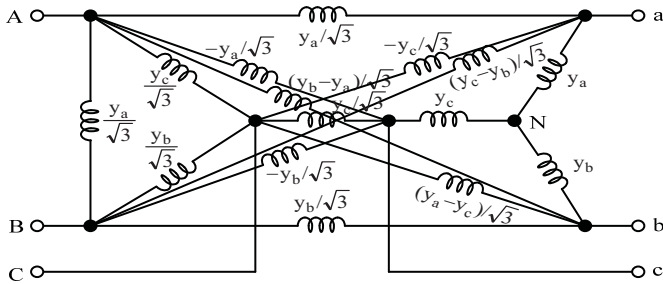

FIGURE II. THE EQUIVALENT CIRCUIT OF A DELTA-WYE THREE-PHASE TRANSFORMER.

III. SIMULATION TECHNIQUE

SIMULINK is professional software for simulating power systems or devices. It has a powerful simulation module, SimPowerSystems. The SimPowerSystems provides various electric power elements for simulation. Users can select necessary electric power elements to build the equivalent circuit of a power system or device, and then to simulate their operation characteristics. For example, the “Elements” library of the SimPowerSystems provides the basic elements such as breakers, ground, transformers, conductors and loads. In this research, the resistors and reactors in SimPowerSystems were used to build the equivalent circuit of the delta-wye three-phase transformer according to the Figure 2. Figure 3 shows the equivalent circuit of the delta-wye three-phase transformer for simulation in SIMULINK.

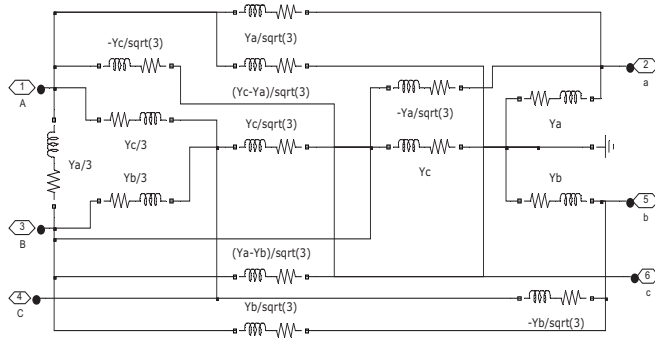

FIGURE III. THE EQUIVALENT CIRCUIT OF THE DELTA-WYE THREE-PHASE TRANSFORMER FOR SIMULATION IN SIMULINK.

IV. TEST SYSTEM

A test system is proposed in this paper for simulating the unbalanced operation characteristics of a delta-wye three-phase transformer. Figure 4 shows the structure of the proposed test system. The test system includes a balanced three-phase voltage source, primary feeders, a delta-wye three-phase transformer, secondary feeders, and a three-phase RL

load. The balanced three-phase voltage source is modified from the element “Three-Phase Source” which can be gotten from the “electrical sources” library of the SimPowerSystems. The primary and secondary feeders are modified from the elements “Three-phase series RLC Branch” which can be gotten from the “Element” library of the SimPowerSystems. The three-phase RL load is modified from the elements “Three-phase series RLC Load” which also can be gotten from the “Element” library of the SimPowerSystems.

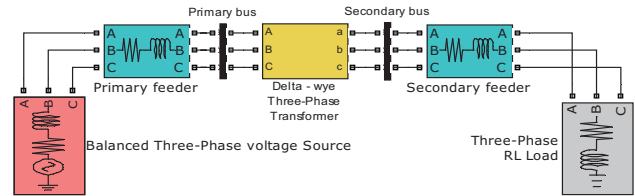

FIGURE IV. THE STRUCTURE OF THE PROPOSED TEST SYSTEM.

The balanced three-phase voltage source is an ideal power source. Its magnitude is set as 11400V line to line. The primary and secondary feeders include three conductors, respectively. Their lengths and impedances are all 100m and $0.131+j0.371\Omega/\text{km}$, respectively. The three-phase RL load consumes 50kvar with 0.8 lagging power factor. The rated capacity of the delta-wye three-phase transformer is 100kVA. The rated voltages on primary and secondary side are 11400V and 220V line to line, respectively. In order to get the information about bus voltages, line currents and power flows, some measuring elements are set in the test system. For making the structure of the test system clear, the adopted measuring elements are all hidden inside the primary and secondary buses.

V. SIMULATION RESULTS

The proposed test system has been built in SIMULINK. Several simulation cases for simulating unbalanced operation characteristics of a three-phase transformer also have been carried out. In the simulation work, the impedances of phase B and C of the delta-wye three-phase transformer were assumed to be equal. The impedance of phase A of the delta-wye three-phase transformer was changed at each simulation case. The impedance ratio (IR) is defined in eqn (1) and the change range was from 50% to 150%. In eqn (1), the basic impedance is the original winding impedance of the three-phase transformer. If the IR is 100%, it means the three winding impedances of the delta-wye three-phase transformer are exactly equal to each other. Besides, the simulation duration for all simulation cases was 0.5s. Simulation results including voltages, currents and unbalance ratios on the primary and secondary sides of the delta-wye three-phase transformer are presented and discussed as follows. The voltage and current unbalanced ratios (VUR and IUR) are defined in eqn (2) and (3), respectively. In eqn (2), the voltages V_A , V_B and V_C are the phase voltages of three-phase transformer. The V_{avg} is the average of the voltages V_A , V_B and V_C . In eqn (3), the currents I_A , I_B and I_C are the line currents of three-phase transformer. The I_{avg} is the average of the currents I_A , I_B and I_C .

$$IR = \frac{\text{winding impedance}}{\text{basic impedance}} \times 100\% \quad (1)$$

$$VUR = \frac{\text{Max}[\|V_{\text{avg}} - |V_A|\|, \|V_{\text{avg}} - |V_B|\|, \|V_{\text{avg}} - |V_C|\|]}{|V_{\text{avg}}|} \times 100\% \quad (2)$$

$$IUR = \frac{\text{Max}[\|I_{\text{avg}} - |I_A|\|, \|I_{\text{avg}} - |I_B|\|, \|I_{\text{avg}} - |I_C|\|]}{|I_{\text{avg}}|} \times 100\% \quad (3)$$

Figures 5 and 6 show the voltage and current waveforms on the secondary side of the delta-wye three-phase transformer, respectively. The simulation results illustrate that the three-phase voltages and currents are unbalanced when the winding impedance of phase A is not equal to phases B and C.

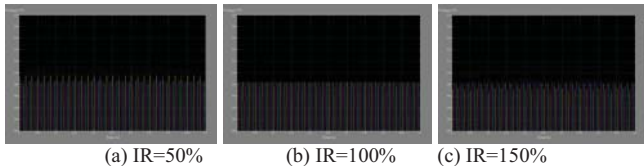

FIGURES V. VOLTAGE WAVEFORMS ON THE SECONDARY SIDE OF THE DELTA-WYE THREE-PHASE TRANSFORMER.

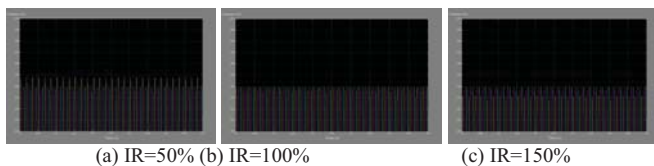

FIGURES VI. CURRENT WAVEFORMS ON THE SECONDARY SIDE OF THE DELTA-WYE THREE-PHASE TRANSFORMER.

Figures 7 and 8 show the VURs and IURs on the primary and secondary sides of the delta-wye three-phase transformer, respectively. The simulation results illustrate that the winding impedances of a three-phase transformer are more different, the unbalance degrees of voltages and currents are larger.

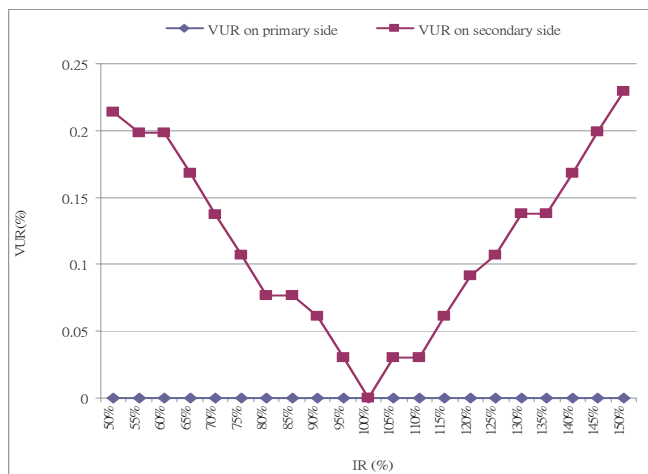

FIGURES VII. VURS ON THE PRIMARY AND SECONDARY SIDES OF THE DELTA-WYE THREE-PHASE TRANSFORMER.

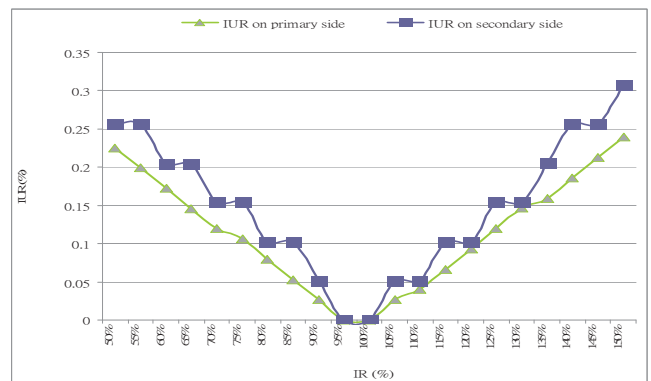

FIGURES VIII. IURS ON THE PRIMARY AND SECONDARY SIDES OF THE DELTA-WYE THREE-PHASE TRANSFORMER.

VI. CONCLUSIONS

The simulation technique for a three-phase transformer with non-identical winding impedances has been presented in this paper. The unbalanced operation characteristics of a three-phase transformer with non-identical winding impedances have been also presented and discussed. The simulation results illustrate that if the winding impedances are not exactly equal to each other, the operation characteristics including voltages and currents will be unbalanced.

Voltage and current unbalances are harmful to electric power devices [5, 6]. The unbalance is larger; the injury to electric power devices is larger, too. Hence, power engineers should take special care whether the winding impedances of three-phase transformers are exactly equal to each other.

ACKNOWLEDGMENT

The authors would like to thank the Ministry of Science and Technology of the Republic of China, Taiwan, for financially supporting this research under Contract No. MOST 103-2221-E-149 -007.

REFERENCES

- [1] Kersting, W. H., *Distribution System Modeling and Analysis*, Taylor & Francis: London, p. 241-292, 2013.
- [2] Chen, T.H. Yang, W.C. Guo, T.Y. & Pu, G.C., Modeling and analysis of asymmetrical three-phase distribution transformer banks with mid-tap connected to the secondary neutral conductor. *International Journal of Electrical Power Systems Research*, **54**(2), pp. 83-89, 2000.
- [3] Mohan, N., *Advanced Electric Drives: Analysis, Control, and Modeling Using MATLAB / Simulink*, John Wiley & Sons: New Jersey, p. 3-6, 2014.
- [4] Smolleck, H.A. & Shoultz, R.R., A classroom method for structuring the bus admittance matrix from synthesis of coupling-free equivalents. *IEEE Transactions on Power Systems*, **7**(1), pp. 383 - 388, 1992.
- [5] Xu, Y. Tolbert, L.M. Kueck, J.D. & Rizy, D.T., Voltage and current unbalance compensation using a static var compensator. *IET Power Electronics*, **3**(6), pp. 977 - 988, 2010.
- [6] Chua, K.H. Yun, S.L. Taylor, P. Morris, S. & Jianhui W., Energy storage system for mitigating voltage unbalance on low-voltage networks with photovoltaic systems. *IEEE Transactions on Power Systems*, **27**(4), pp. 1783 - 1790, 2012.